

HEWLETT-PACKARD JOURNAL



Cover: LIFE TEST OF A NEW INK RECORDER; see page 2

See Also: ADVANTAGES OF DIRECT-COUPLED DIFFERENTIAL
DATA AMPLIFIERS; page 13

ERRORS IN DATA AMPLIFIER SYSTEMS; page 17

JULY 1967

Pressurized Ink Recording on Z-Fold Strip Charts

A pressure-modulated inking system and contactless pen-tip position feedback are two of many innovations in this new eight-channel recorder.

By Robert A. Sanderson

MOST OF TODAY'S OSCILLOGRAPHIC RECORDERS produce good, readable traces, whether they do it by heat, light, ink, or some other means. However, each method has special advantages. Optical recorders have the highest frequency response. Thermal recorders have low initial cost and are the least complicated. And when it comes to producing finished records with desirable properties, the champion is definitely ink.

Pressurized inking systems produce higher-quality traces than any other method; yet they use papers which are much less expensive than those needed for other methods. Capillary ink systems use the least expensive chart papers of all.

The best inked traces have high resolution. They are reproducible and permanent. The paper is durable. All other recording techniques fall short of ink's performance in one or more of these characteristics.

But ink has had problems, too. Most of them stem from the difficulty of handling ink in a recorder and not from deficiencies in the printed record — provided, of course, that the trace is continuous and no smudges are present.

Cover: This Model 7848A Ink Recorder is being subjected to a programmed life test designed to check its reliability. The test includes start-stop cycles, speed changes, and high- and low-frequency input signals of several different waveforms. See also page 9.

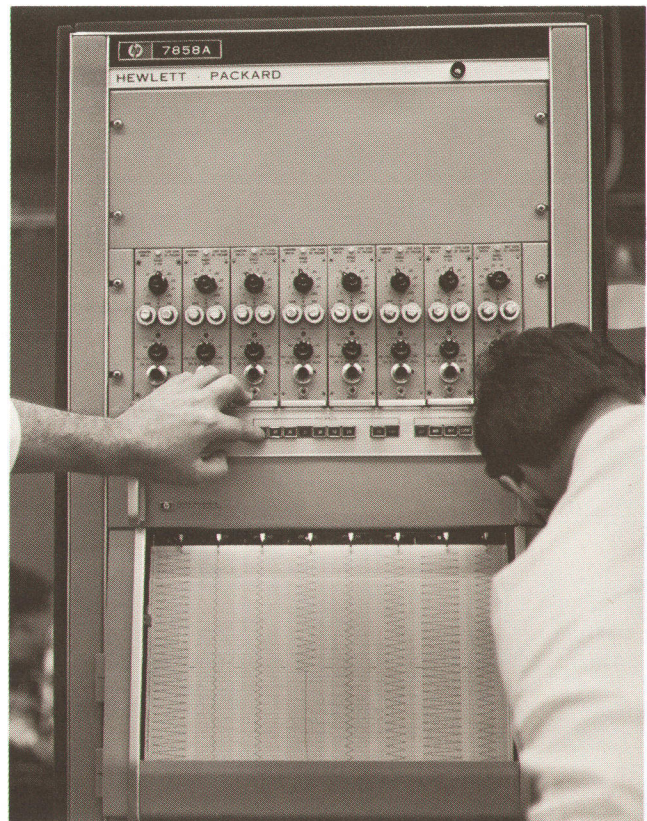

Fig. 1. Two engineers put a new HP Ink Recording System through its paces. This one has a roll-paper takeup, but it can also use Z-fold charts. New black ink 'dries' on contact with paper and comes in easily replaced cartridges.

Capillary ink systems use inks which can dry in the stylus tip in a relatively short time if the system is idle. Freeing the ink passages is a messy process involving the use of cleaning wires or solvents or both. Capillary systems also have a tendency to throw ink if the tip velocity of the pen is too high. This often becomes a problem, because high-performance pen-drive systems can produce tip velocities about ten times faster than a capillary system can cope with.

Replenishing the ink supply in either a capillary system or a high pressure ink system can be troublesome, too. In most systems, recording has to be stopped while the ink reservoir is refilled. And, although more modern recorders use neater methods, some systems still require that ink be poured into the supply reservoir from a bottle.

High-pressure ink systems suffer from an inability to use Z-fold paper. Z-fold chart paper is much more convenient than rolled charts because any part of a Z-fold record can be examined easily at any time. With rolled

paper, there is no way to examine earlier portions of a record without first unrolling everything that came afterwards. High-pressure ink systems can't use Z-fold charts because Z-fold paper is serrated across the chart to make it fold properly. When the pens pass over a fold, ink under pressure runs out through the serrations and makes a spot on the paper. The pens also lift slightly when they go over a fold and this, too, lets ink run out.

First-hand experience with one or more of the problems of early ink recorders has provided enough incentive for many users to seek other recording techniques. Nonetheless, no finished record is more universally wanted or more useful than an inked record.

New Ink Recorder

It is now possible to make inked records without encountering the traditional problems of handling ink. A new eight-channel ink recorder (Fig. 1) embodies a number of new approaches to these old problems.

The new recorder has a pressurized ink system in which the ink pressure is modulated to maintain continuous, uniform traces at both high and low pen-tip velocities. The ink has been specially developed; it will not dry in the pen tips even if the recorder is idle for several months.

Replenishing the ink supply is a simple matter of replacing a disposable plug-in refill cartridge. One cartridge serves all eight channels, and there is no need to stop the recorder to change cartridges.

Most important for the user is the new recorder's ability to use either Z-fold paper or rolls (Figs. 1 and 2). The new ink system is a low-pressure system which doesn't force out a large amount of ink when the pens pass over the folds in Z-fold charts.

Non-smudging, Non-drying Ink

An important member of the ink-recorder engineering group is a full-time chemist. Thus the development of the ink for the new recorder was an integral part of the design of the whole system.

Development and testing of more than 150 ink formulas produced at least 25 that would do an adequate job in most environments. The one selected continues to perform at 95% humidity and at 40°C (104°F). Further improvements are being made on a continuing basis.

Unlike the water-based inks used in capillary inking systems, the new ink has a glycol base which is very slow to evaporate (it has a low vapor pressure).

In the pens the ink stays fluid indefinitely because it is not exposed to air. Each pen is held against the paper

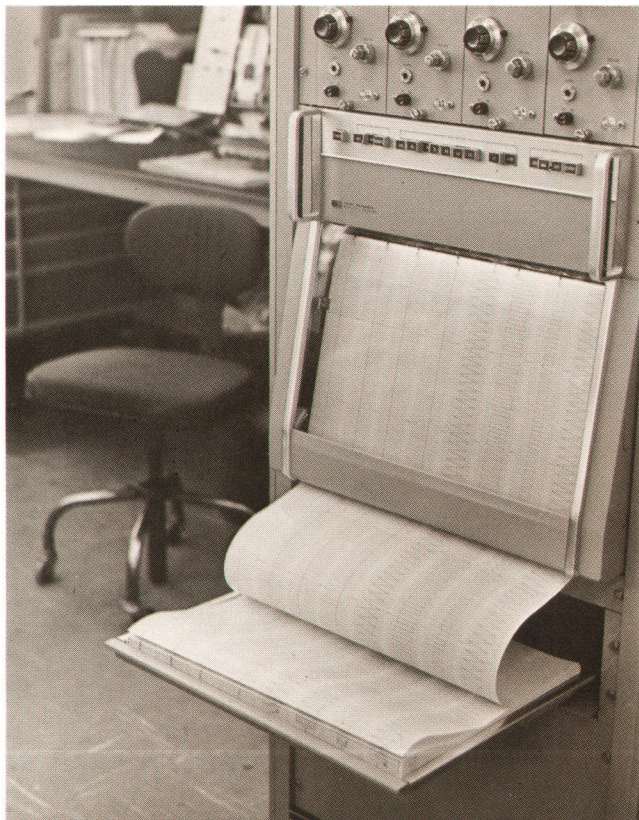

Fig. 2. Unlike most pressurized ink recorders, the new recorder can use Z-fold chart paper, which is much more convenient than rolled paper because it allows any part of a record to be examined easily, even while recording.

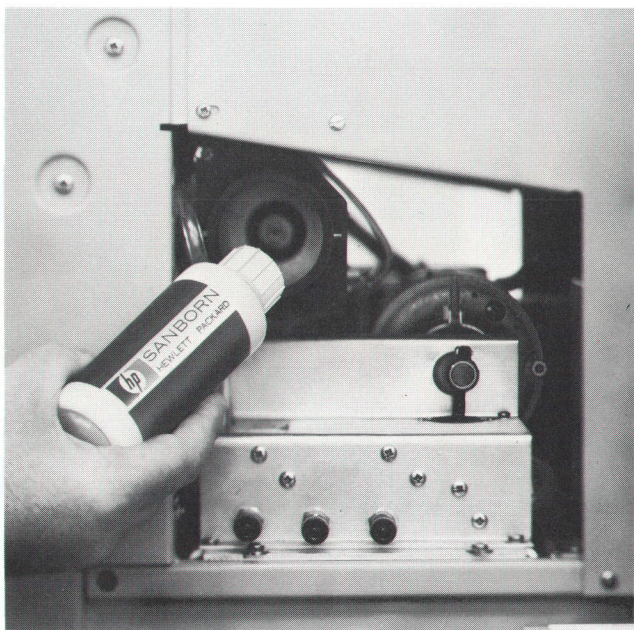

Fig. 3. Replacing the ink cartridge in the new recorder can be accomplished while the machine is operating. No mess is involved. Each 4 oz. cartridge is good for 1000 miles of recorded line.

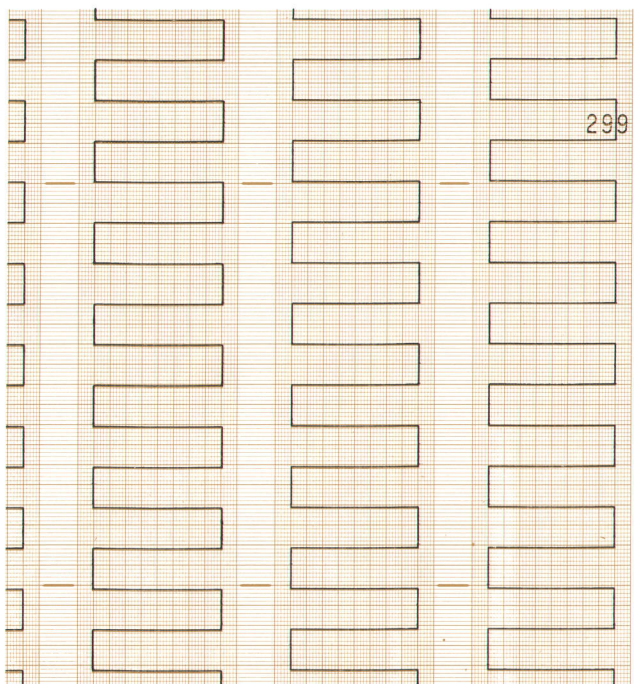

Fig. 4. Chart paper used for ink recording has eight channels, each 4 cm wide with 50 divisions. Recorded square wave shows how ink-pressure modulation prevents loss of trace for step-function inputs.

with a force of about 20 grams, even when the recorder is not in use. Hence there is always a tight seal between the pen and the paper, separating the ink from the air. The pen tips are made of tungsten carbide to keep them from wearing out too quickly under the high pen force.

In use, the ink 'dries' instantly through absorption into the paper surface. It is formulated to give a high-resolution, near-black trace on glossy paper. This combination appears to meet almost everyone's conception of the highest-quality type of record.

The ink comes in 4 oz. plug-in cartridges, each good for 1000 miles of recorded line (see Fig. 3). Cartridges can be replaced during recording, since there is a built-in reserve supply. An indicator light comes on when the cartridge in use is empty.

Z-fold Chart Paper

Paper for the ink recorder was selected after testing more than 100 samples from different manufacturers.

Humidity proved to be the undoing of most of the papers tested. Under 95% humidity most papers swell and their coatings soften. The soft coating can clog the pen tips. Swelling can impair accuracy if the paper's dimensions change more than the amount that can be compensated by recalibrating the system. The paper finally selected has a coating which softens little in high humidity, and its dimensions change less than any of the papers tested.

Other tests given the paper samples were microscopic examination for trace sharpness, and water immersion and charring tests to make sure that the traces wouldn't spread, wash off, or fade.

The chart paper selected is thin and strong, and has a smooth, glossy surface. The surface allows a high pen pressure with a minimum of friction forces and minimum chance of leakage. The paper comes in 500-foot rolls or 500-sheet Z-fold packs. Footage remaining on the roll is printed on the edge at one-foot intervals, and each page of the Z-fold pack is numbered. Each recording channel is four centimeters wide and has 50 divisions (see Fig. 4).

Pressure-modulated Ink System

To maintain an adequate trace with varying chart speeds and signal conditions, an entirely new pressurized inking system has been developed.

The purpose of ink pressure is to overcome changes in the ink flow rate caused by 1) changes in the pen speed and 2) accelerating forces created by the rectilinear pen mechanism (more about this later).

In the new system the ink pressure is not constant,

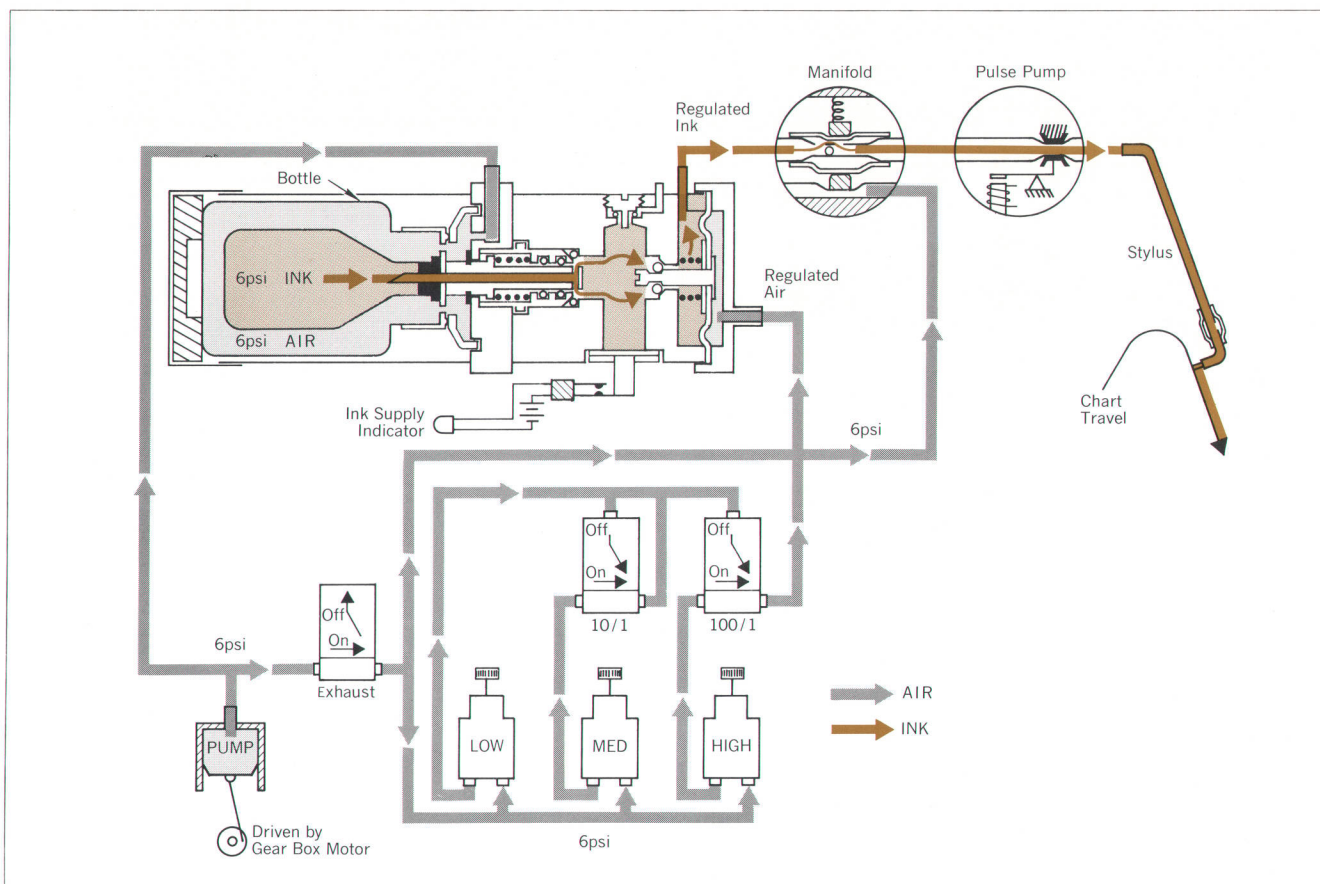

Fig. 5. Diagram of the pressure-modulated ink supply system. One pen is shown, although the manifold supplies all eight.

but is a function of the chart speed and the input signal.

The ink system (see Fig. 5) operates on air pressure supplied by a small piston pump on the chart drive motor. Ink pressure is controlled by regulating the air with electrically-operated valves.

The ink system turns ON automatically when the chart is driven. Air from the pump (at about 6 psi) is connected directly to the plug-in ink cartridge to pressurize the ink, which is in a flexible sac in the cartridge. Air is also supplied to each of the eight channel shutoff valves to turn them on.

Ink from the supply cartridge enters the ink regulator where its pressure is dropped to one of three pressures, depending upon the chart speed. For chart speeds of 0.025 to 0.25 mm/s the ink pressure is 0.4 psi; for speeds of 0.5 to 2.0 mm/s, the pressure is 1.0 psi; and for speeds of 2.5 mm/s to 200 mm/s the pressure is 3.0 psi.

Pressure from the three pressure regulators is adequate to maintain a continuous trace for most recorded signals. However, it is not adequate for recording some

step functions. Here the change in flow rate in the pen tube can be large and the acceleration forces along the tube are sometimes opposite to the direction of ink flow.

To overcome the negative 'g's' in the pen tube and maintain the flow at the tip when a step function occurs, a short pressure pulse is applied to the ink by a relay-driven pump behind the pen. The pump is electrically in series with the drive coil of the pen motor. It operates at all times, but its effect is small except when the signal being recorded has a rise time faster than 10 ms and an amplitude above 10 mm on the chart.

Under step conditions a complete loss of trace would occur if there were no compensating pressure pulse. As the recorded square wave of Fig. 4 shows, the compensating pulse prevents this loss of trace. Under conditions of slower rise times or comparatively lower-frequency signals, the smaller pressure pulses from the pump serve to prevent thinning of the trace. There is always sufficient pressure to maintain a trace of near-constant width (about 0.009" wide) without the penalty of excess pressures which can create wider or wet traces.

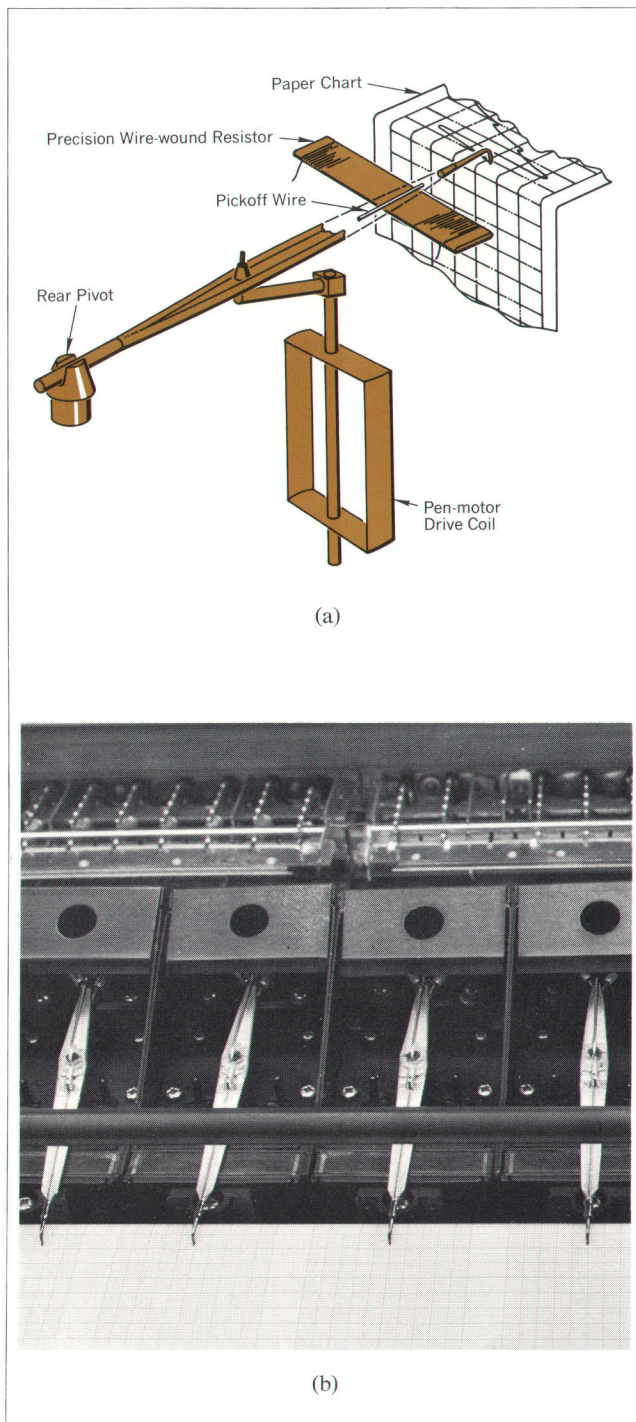

Fig. 6 (a). Pen drive mechanism is simple, yet very linear. As pen motor rotates, pen tip describes a line that is straight within 0.005" across 4 cm channel. Position-sensing transducer is located near pen tip to detect linkage errors. Pickoff wire does not touch wirewound resistor, so transducer wear is not a problem. (b). Transducer resistors can be seen just below transverse rod in photograph.

Another important part of the ink system is a tiny hydraulic accumulator in the form of a rubber boot mounted on the pen near the tip. It does two things.

The pulse pump creates two pulses during pen deflections which occur in response to step inputs. One pulse is for the accelerating pen-motor current and one is for the decelerating current. A low-pressure point occurs approximately half way between these pulses, near the midpoint of the pen stroke. The tip accumulator lengthens the duration of the first pulse so that it overlaps the second. This eliminates the dip in pressure.

Second, positive and negative pressure variations occur at the pen tip as the pen moves back and forth across the channel. To make the pen move in a straight line as the pen motor rotates, the distance from the pivot point to the pen tip must change; it must be minimum when the pen is at the center of the channel and maximum when the pen is at the edges. The result is a back and forth motion of the pen which accelerates and decelerates the ink and causes the pressure at the tip to vary. The boot reduces these pressure variations, thereby easing the problems of controlling the ink under all recording conditions.

The ability of the new recorder to use Z-fold paper is primarily due to its only-when-needed ink pressure. The absence of excess pressure keeps the ink from making large wet spots as the pens are lifted slightly by the creases in the paper.

Servo Pen Drive

Complementing the new ink supply system is a completely new servo pen-drive system.

Fig. 6 is a diagram of the simple pen drive mechanism used in the new recorder. This mechanism converts the reciprocating rotary motion of the pen motor to a reciprocating linear motion of the pen tip across the recording channel. With the chart stationary, the line described by the pen tip is straight within $\pm 0.005''$ across the width of the channel.

The purpose of any pen-drive system is to convert a variable electrical input signal to an accurately proportional displacement of the pen tip. Tending to decrease the accuracy of this conversion are such things as nonlinearities in the pen motor and in the linkage, twisting, bending, and vibration, especially in the stylus, and of course, friction.

To counteract these sources of error, position feedback is used. A transducer senses the displacement of the pen so that it can be compared with the input signal and the current in the pen motor adjusted accordingly.

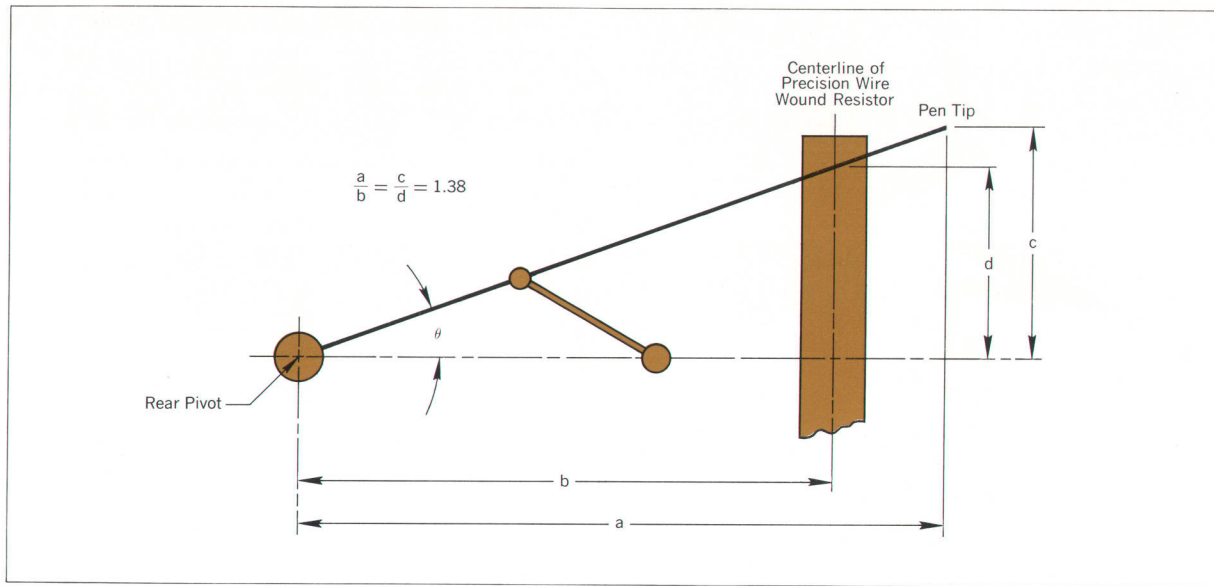

Fig. 7. Transducer near pen tip is linear. Ratio of tip motion to pickoff-wire displacement is 1.38 to 1.

Ideally, an error-sensing transducer to eliminate all mechanical errors should be located at the pen tip. However, the tip is a difficult place to put a transducer without hiding the tip from view. What's more, the inertia of a given transducer increases as the square of the distance from the pivot. Therefore, a location about an inch from the tip was selected for the moving element of the transducer in the new recorder (see Fig. 6).

Advantages of this transducer location over other possible locations proved to be many. Rotary transducers could have been located either at the pen-motor shaft or at the rear pivot, but transducers in these locations would have to be nonlinear because the displacement of the pen tip isn't a linear function of the shaft angles. Another disadvantage of these locations is that the transducers wouldn't be able to detect position errors caused by slack in the mechanism or bending of the stylus.

The transducer near the pen tip is linear. The ratio of tip motion to transducer displacement is a constant 1.38 to 1 (see Fig. 7). Displacement errors are detected precisely enough to make typical recorders linear within 0.25%. Linearity is specified conservatively at 0.5%.

No-contact Error Sensing

Two elements make up each error-sensing transducer. One is a fixed wire-wound resistor whose resistance varies linearly with the distance from either end. The other element is a pickoff wire attached to the pen, but insulated from it. The wire moves over the resistor as the pen moves from side to side. *The wire does not touch*

the resistor. Clearance is about 0.040 in. Hence wear and drag are avoided and frequency response is improved over that of knife-edge/slide-wire transducers.

In operation, 20 kHz square waves, 180° out of phase with each other, are applied to opposite ends of the resistor. When there is no input signal these square waves

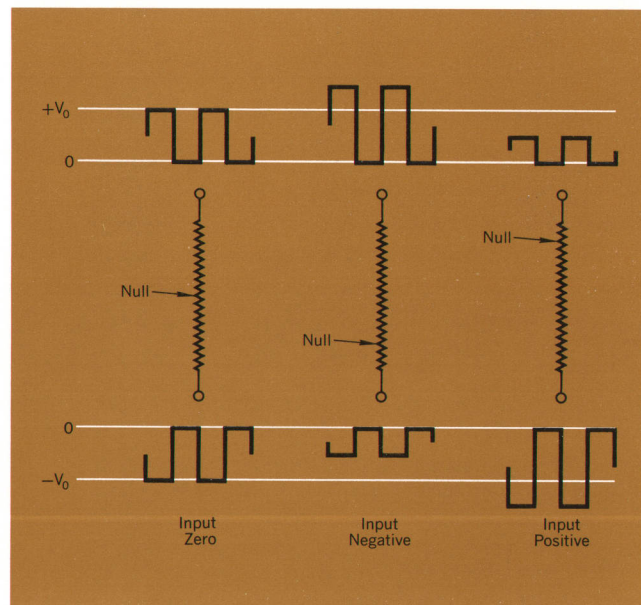

Fig. 8. 20 kHz square waves, 180° out of phase, are applied to ends of transducer resistor, creating a null which is shifted as a function of the input signal. Servo system senses pen position relative to the null and drives pen to follow null.

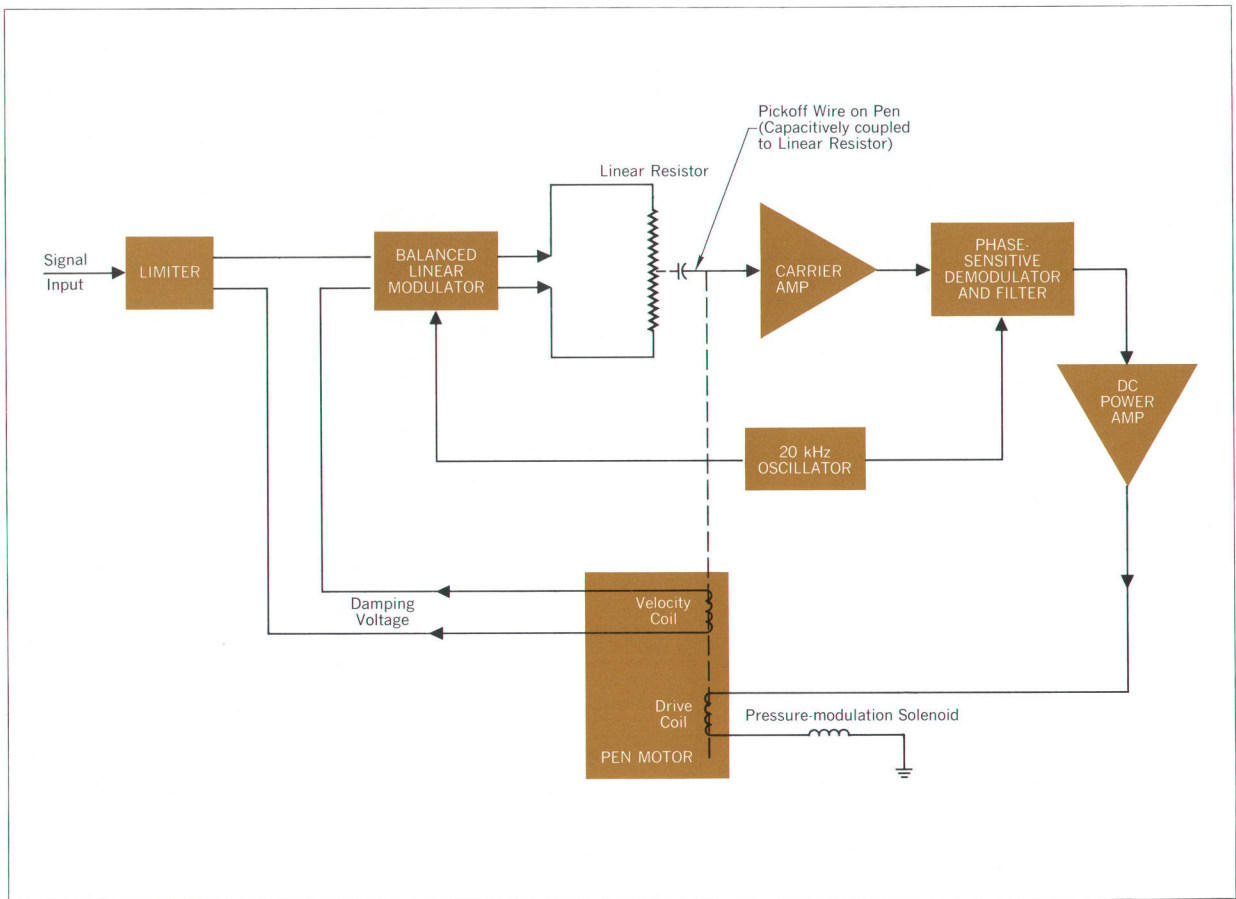

Fig. 9. Electrical drive circuit for one channel of ink recorder.

have equal amplitudes. Thus a zero-voltage point or null is created exactly in the center of the resistor (see Fig. 8).

For a non-zero input signal, the amplitudes of both square waves are varied as functions of the input signal. This causes the position of the null on the resistor to shift.

Capacitive coupling between the resistor and the pick-off wire (about 0.1 pF) enables the pickoff wire to sense when the null has moved away from the pen. The 20 kHz voltage produced in the pickoff wire is transmitted to a carrier amplifier. The amplified 20 kHz signal is demodulated by a phase-sensitive demodulator, then amplified again and applied to the pen motor to cause the pen to follow the null.

Electrical Drive Circuit

The electrical drive circuit is shown in the simplified block diagram, Fig. 9. The input signal first passes through a limiter, to establish the limits of pen movement, and is then applied to the 20 kHz modulator which establishes an ac null position along the position-sensing

resistance. The electrode on the writing pen picks up an ac voltage which represents pen position with respect to the null. This ac voltage goes to the demodulator, which supplies a dc voltage when the pen is not at the null. The polarity of the dc voltage indicates the direction from pen to null. The driver amplifier then supplies current to the pen motor which drives the pen to follow the null.

New Pen-drive Motor

The design of the pen-drive motor for the ink recorder is somewhat different from others in this class of electro-mechanical elements. The conventional D'Arsonval galvanometer used in older recorders has a large external magnet and a soft-iron core (see Fig. 10). This results in a heavy, bulky unit, which has a strong external stray magnetic field. When several units are placed side-by-side these stray fields interact, so that each magnet affects the sensitivity of its neighbor. As a result, special adjustments and shielding are required for multi-channel installations.

The new pen-drive motor uses a magnetized core and has an external soft-iron shell. In this way, the entire magnetic structure acts as its own magnetic shield to reduce the stray external field and to give a more compact, lighter, and less expensive unit which requires no special adjustments or shielding in multi-channel use. The pen motor is designed for at least 10,000 hours of normal operation.

Because the pen motor is used with a servo positioning system there is no need for a torsion rod or a centering spring. Restoring force is provided by the electrical drive circuit. With power off, the pen can be moved freely from one position to another and will remain at rest wherever it is placed.

Speed-reduction Mechanism Simplified

The chart drive mechanism includes the chart drive motor and five step-down reduction units which provide fourteen different chart drive speeds. The mechanism is shown in Fig. 11.

When the solenoids of all five reduction units are OFF, each reduction unit operates at the stepdown ratio shown in Fig. 11, for an overall stepdown ratio of 8000:1. When the solenoids of all five reduction units are ON, each reduction unit operates 'straight-through,' for an overall ratio of 1:1. (There is also a fixed speed reduction of

15:1 in the system.) Different combinations of solenoids, selected by the chart speed buttons on the front panel, provide intermediate overall ratios, to give fourteen different chart speeds between 0.025 and 200 mm/s. The drive motor can be turned on and off remotely, and the speeds can be selected remotely.

All five gear boxes are simple in design and of similar construction. Many of their parts are interchangeable. This contributes to economy and maintainability.

The drive system is also designed for a normal life of not less than 10,000 hours with periodic lubrication.

Life Testing for Reliability

The new recording system is being subjected to rigorous testing. A programmed life test has been designed to expose the system to many of the worst conditions it might meet in practice (see cover and p. 2). In this test, the recorder turns on and off six times per hour (except power supply); the clutches operate 12 times per hour (this is estimated to be ten times normal use); the recorded trace is a combination of waveforms consisting of 13% signals with frequencies of 10 Hz to 200 Hz and 87% slow signals and no signal; each stylus writes about 3000 ft/hr.

It is estimated that one hour of this programmed life test is equivalent to 15 hours of normal operation for the

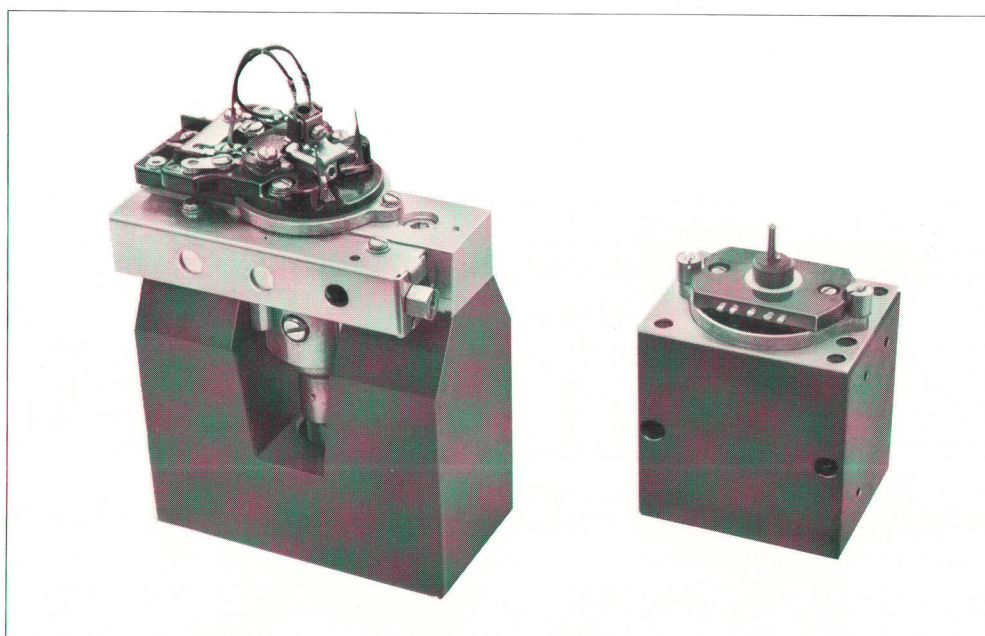

Fig. 10. New pen motor (r), is lighter and smaller than older type (l), and has smaller stray external magnetic field.

Signal Conditioning Preamplifiers for Ink Recorder

8800 Series Single Channel Preamps

HP Model	Features	Principal Uses
8801A	Low-gain dc differential amplifier Sensitivity 5 mV/div to 5000 mV/div ■ Accuracy $\pm 1\%$, Linearity ± 0.25 div ■ Frequency range dc to 10 kHz ■ Zener-stabilized calibrated zero suppression ■ Internal calibration source	General use in a majority of recording situations from dc to the maximum usable frequency of the recorder
8802A	Medium-gain dc differential amplifier Sensitivity 1 mV/div to 1000 mV/div ■ Other features similar to 8801A	General (see 8801A)
8803A	High-gain dc differential amplifier Sensitivity 1 μ V/div to 5 V/div ■ Accuracy $\pm 1\%$ to $\pm 2\%$, Linearity ± 0.25 div ■ Frequency range dc to 110 Hz ■ Calibrated zero suppression ■ Floating, guarded input, 160 dB CMR (dc) ■ High input resistance ■ High stability	Versatile general-purpose dc amplifier. Used where high sensitivity, stability, and operational flexibility are required
8805A	Carrier amplifier Sensitivity 10 μ V/div to 2 mV/div ■ Calibrated zero suppression ■ Internal transducer excitation source ■ Gage factor control adjusts for transducer sensitivity	Measurement of strain, displacement, velocity, etc. Excites transducers and detects their outputs
8806B	Phase-sensitive demodulator Reference frequency range 50 Hz to 40 kHz ■ Front-panel plug-in calibrated phase shift ■ High-impedance, transformer-isolated signal and reference inputs	Monitoring performance of ac servo systems
8807A	ac to dc converter Sensitivity 1 mV/div to 10 V/div (rms) ■ Frequency range 50 Hz to 100 kHz ■ Calibrated zero suppression ■ Floating, guarded 1 M Ω input ■ Unusually fast envelope response ■ Scale expansion for 0.02% resolution	Measuring ac voltages (and currents with current probe). Used like ac differential voltmeter for monitoring and recording amplitude stability of ac sources
8808A	Logarithmic ac to dc converter Sensitivity: 100 μ V/div = bottom scale ■ Accuracy ± 1 dB ■ Frequency range 10 Hz to 100 kHz ■ 100 dB dynamic range	Monitoring ac levels with wide dynamic ranges, e.g., sound level recording, vibration analysis, etc.
8809A	Signal coupler Switch selected input impedance ■ Full-scale positioning	Used where great flexibility and versatility are not required and cost is a consideration. Basic sensitivity must be suited to application or a fixed external attenuator must be used

Eight-Channel Preamps (all channels identical)

8820A	All-silicon low-gain dc amplifier Sensitivity 50 mV/div to 5 V/div ■ 1 M Ω input resistance ■ Polarity reversal switch in each channel (minimal effect on zero position) ■ Individual or simultaneous calibration of all channels	Telemetry recording, analog computer output, or general use.
8821A	All-silicon medium-gain dc amplifier Sensitivity 0.5 mV/div to 5 V/div ■ Floating, guarded input on 6 most sensitive ranges, differential on 6 other ranges ■ 9 M Ω input resistance ■ CMR 100 dB on most sensitive range	General-purpose use over recorder bandwidth

Medical Preamplifiers

HP Model	Description and Use
350-1000B	dc preamplifier for recording outputs of instruments used for gas analysis, monitoring CO ₂ concentration, etc. Also for densitometer and cardiometer recording, etc.
350-1100CM	Carrier preamplifier , used with transducer for recording pressure, flow, velocity, displacement, force, etc. Medical uses include recording venous, arterial, gastrointestinal, respiratory and other pressures, or forces in prosthetic appliances.
350-1300C	dc coupling preamplifier , similar to 350-1000B but with lower sensitivity.
350-1500A	Low-level preamplifier , used with one of eight plug-ins for monitoring thermocouples, EEG/ECG, strain gages, Waters oximeters, Waters earpieces or cuvettes, oxygen cells. Also for measuring galvanic skin resistance or blood flow (thermal dilution method).
350-2700C	High-gain ac preamplifier for general use, including single channel EEG during surgery, fetal electrocardiography, etc.
350-3000C	Medical carrier preamplifier . Used like 350-1100CM. Has switches for averaging, pulsatile, and catheter operation.
350-3200A	ECG/general-purpose preamplifier . Similar to 350-2700C. Operates with Waters Nitrogen Meter, Beckman CO ₂ Analyzer, etc.
350-3400A	Cardio-tach preamplifier . Measures average heart rate, time between 'R' waves, etc. Also for long-term monitoring.
350-3600A	pH preamplifier . For recording pH or pCO ₂ in whole blood, or general-purpose pH recording in 3-11 pH range.
350-3700B	Integrating preamplifier . Used as integrator or summator.
350-5000B	Respiratory preamplifier . With 2 carrier preamps and an oscilloscope, measures mechanical resistance and compliance of lungs.

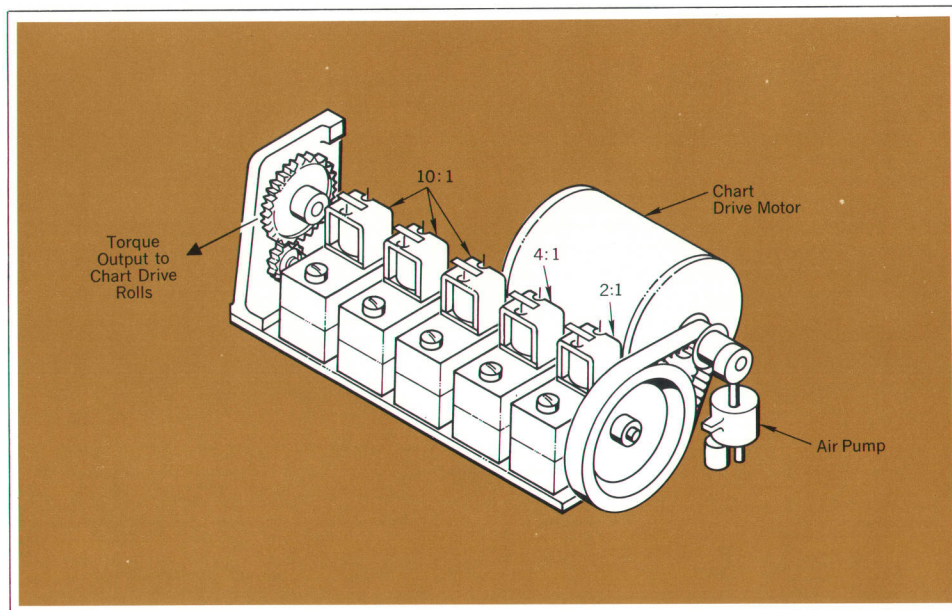

Fig. 11. Simplified chart drive mechanism gives 14 chart speeds with relatively few parts, many of them interchangeable. Different speeds are obtained by switching solenoids to engage or disengage the five reduction gears in different combinations.

pen motor and stylus, 10 hours of normal operation for the chart drive train, and one hour of normal operation for the power supply and amplifiers. Normal life estimates for the various parts of the recorder are based on this test and these estimated equivalence factors.

Preamplifiers for Complete Recording Systems

So far this discussion has been limited to the new ink-writing recorder. However, the recorder is only one part of a recording system. Preamplifiers are needed to complete the system, one for each of the eight channels.

The table on p. 10 shows the preamplifiers that will operate with the new recorder.

Three types of preamplifiers are available. One is a series of single-channel plug-in units which perform several specialized signal-conditioning functions. Another type consists of lower-cost eight-channel units in which all channels are alike. The third is a series of single-channel units primarily for bio-medical applications.

All of the preamplifiers listed in the table are designed to drive the single-ended, ground-referenced, 5 k Ω inputs of the ink recorder's amplifiers. All of the preamplifiers also have facilities for precise gain adjustments and for setting the zero position of the writing pen to any point on the 4-cm channel.

Acknowledgments

Important contributions to the ink recorder's development have been made by many, many individuals during the past several years. I can only mention a few here.

Dr. Arthur Miller's ideas on pressure modulation were the beginning of the project. The servo system was designed by J. William Sauber. George Larsen developed the new family of inks. The mechanical design was done by Ustun Germen, Richard L. Weddleton, Michael A. Feldstein, Daniel H. Dudley, and Richard E. Stanley. John C. Allen and Steven I. Zoltan designed the gearbox and the pen motor, respectively. Substantial contributions to the program were also made by Donald M. Brown, Edward W. Nork, C. Miller Ferguson, and Eugene J. Picard. ■



Robert A. Sanderson

Bob Sanderson joined HP in 1962. Before that, he had spent five years in the engineering and product development of magnetic tape drives and card collators, and one year as project engineer for the development of a color-film processor. Since 1963 he has been project engineer for the Model 7848A Ink Recorder project. He holds a patent on a card-guiding apparatus and has one pending on the ink supply system used in the new recorder.

Bob received a BS degree in machine design from the Rhode Island School of Design in 1956. Between his first two years of college and his last two years, he spent two years in the U. S. Army Ordnance Corps. He is married, has four children, and enjoys skiing, camping, and flying.

SPECIFICATIONS

HP Model 7848A Recorder

(These specifications are for the recorder only. For preamplifier descriptions, see Table, p. 10.)

Chart Drive Specifications

CHART SPEEDS: Fourteen, selected by seven speed buttons and X1 and X100 buttons. Speeds are: 0.025, 0.05, 0.10, 0.25, 0.50, 1.0, 2.0, 2.5, 5, 10, 25, 50, 100, and 200 mm/s. Speed accuracy $\pm 0.25\%$ with 60-cycle line.

REMOTE CONTROL: By pressing remote button; also provides remote indication of system readiness.

PAPER WEAVE: Less than 0.5 mm. Defined as total lateral motion of any amplitude line on the chart as paper passes through the recorder, with respect to any fixed reference point on the recorder.

RECORDING CHART: 500-foot rolls or 500-sheet Z-fold pack. Eight four-centimeter channels, divided into 50 divisions. Time lines every 1 mm. Footage remaining indicated on right edge at 1-foot intervals (rolls) or each sheet numbered (Z-fold packs).

Ink System Specifications

INK SUPPLY: Plug-in plastic bottle, 4-oz. contents. Front panel indicator shows when bottle is empty. Reserve supply of 1/2 hour approximately.

INK FEED: Pressurized, with individual pressure modulation in each channel.

INK: Non-smudging, dry-on-contact, permanent. Diazo reproducible.

Recorded Line Specifications

TRACE WIDTH: Nominally 0.010", may broaden to 0.020" at lowest chart drive speeds.

RECTILINEAR ACCURACY: Line is straight within 0.005" over 4 cm displacement, with pen pressure between 15 and 25 grams.

Marker Specifications

LEFT-EDGE MARKER: Push-button selection of pulse at 1-s or 1-min intervals from internal synchronous motor timers. Indication is static displacement, approximately 2 mm. May operate remotely, or from +1.5 volt signal into internal amplifier.

RIGHT-EDGE MARKER: Push-button event marker. Indication is static displacement, approximately 2 mm. May be operated remotely by contact closure, or from +1.5 volt signal into internal amplifier.

Recording Specifications

SENSITIVITY: 0.1 volt input gives one division deflection $\pm 2\%$.

LINEARITY:

Method 1: After calibrating for zero error at center scale and +20 divisions, error is less than ± 0.25 division at any point on printed coordinates.

Method 2: After calibrating for zero error at lower and upper end of printed coordinates, error is less than ± 0.5 division at any point on scale.

NOISE: < 0.1 div peak-to-peak.

FREQUENCY RESPONSE: dc to 160 Hz, with response not more than 3 dB down at upper limit, measured at 10 div. peak-to-peak excursion with damping set for 4% overshoot on square waves.

RESPONSE TIME: Varies with total deflection, not more than 4% overshoot:

Peak-to-peak deflection	10% to 90% square wave response time
10 divisions	3 milliseconds
25 divisions	4 milliseconds
50 divisions	6 milliseconds

BANDWIDTH-AMPLITUDE PRODUCT: 60 Hz for full-scale deflection. See chart.

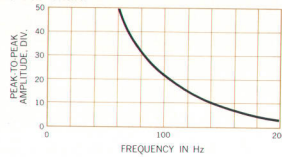

Prices:

EIGHT-CHANNEL SYSTEM FOR USE WITH 8800 SERIES PREAMPLIFIERS

Model 7858A Eight-Channel Recording System... \$9,650.00 consisting of:

- 1) 7848A Eight-Channel Ink Recorder
- 8) 07850-61000 Driver Amplifiers
- 1) 08800-63000 or 8800-03A Preamp Power Supply
- 1) 07858-69000 Cabinet
- Option 01: less Cabinet Deduct \$425.00
- Option 02: Portable Cases No Change
- Option 03: Z Fold Paper Takeup Add \$100.00
- Option 08: 50 Hz Operation Add \$50.00
- Option 09: 230 Volts, 9900-2029 Transformer installed in cabinet Add \$100.00

8800 SERIES PRECISION SIGNAL CONDITIONERS:

- 8801A Low Gain Preamplifier \$275.00
- Option 01: Bench Top Unit, includes 860-500 Power Supply and 860-1400 Portable Case Add \$310.00
- 8802A Medium Gain Preamplifier \$325.00
- Option 01: Bench Top Unit, includes 860-500 Power Supply and 860-1400 Portable Case Add \$310.00
- 8803A High Gain Preamplifier \$600.00
- Option 01: Bench Top Unit includes 860-500A Power Supply and 860-1400 Portable Case Add \$325.00
- 8805A Carrier Preamplifier \$400.00
- Option 01: Bench Top Unit, includes 860-500C Power Supply and 860-1400 Portable Case Add \$325.00
- Option 02: 462-237 Harmonic Filter Kit installed for use of 8805A with 267 or 268 transducers Add \$30.00
- 8806B Phase Sensitive Demodulator \$495.00
- Option 01: Bench Top Unit, includes 860-500 Power Supply and 860-1400 Portable Case Add \$310.00
- Option 02: 8806-01B Variable Frequency Phase Shifter Plug-in, 50 Hz to 40 kHz Add \$175.00
- Option 03: 8806-02B Calibrated Phase Shifter Plug-in, 60 Hz Add \$125.00
- Option 04: 8806-03B Calibrated Phase Shifter Plug-in, 400 Hz Add \$125.00
- Option 05: 8806-04B Calibrated Phase Shifter Plug-in, 5 kHz Add \$125.00

- 8807A AC to DC Converter \$700.00
- Normally supplied with 08807-60040, 400 Hz Filter for signal frequencies from 330 to 100 kHz.
- Option 01: 08807-60030 60 Hz Filter for signal frequencies from 50 Hz to 100 kHz No Charge when Substituted
- Option 02: 08807-60050 DC Plug-in No Charge when Substituted
- Option 03: Bench Top Unit, includes 860-500 Power Supply and 860-1400 Portable Case Add \$310.00
- 8808A Log Level Preamplifier \$625.00
- Option 01: Bench Top Unit, includes 860-500 Power Supply and 860-1400 Portable Case Add \$310.00
- 8809A Signal Coupler \$110.00
- Option 01: Bench Top Unit, includes 860-500 Power Supply and 860-1400 Portable Case Add \$310.00

EIGHT-CHANNEL SYSTEM FOR USE WITH 8820A OR 8821A EIGHT-CHANNEL PREAMP BANK

Model 7878A Eight-Channel Ink Recording System... \$8,600.00 consisting of:

- 1) 7848A Eight-Channel Ink Recorder
- 8) 07850-61000 Driver Amplifiers
- 1) 07878-69000 Cabinet
- Option 01: less Cabinet Deduct \$425.00
- Option 02: Portable Cases No change
- Option 03: Z Fold Paper Takeup Add \$100.00
- Option 08: 50 Hz Operation Add \$50.00
- Option 09: 230 Volt Operation, 9900-2029 Transformer installed in cabinet Add \$100.00

EIGHT-CHANNEL PREAMPLIFIERS:

- 8820A Low-gain dc amplifier \$1,150.00
- 8821A Medium-gain dc amplifier \$2,400.00

EIGHT-CHANNEL SYSTEM FOR USE WITH 350 SERIES PREAMPS

Model 7868A Eight-Channel Ink Recording System... \$10,250.00 consisting of:

- 1) 7848A Eight-Channel Ink Recorder
- 8) 07850-61000 Driver Amplifiers
- 8) 350-500B Preamp Power Supplies
- 2) 00350-63010 Preamp Racks
- 1) 07868-69000 Cabinet
- Option 01: less Cabinet Deduct \$425.00
- Option 02: Portable Cases No change
- Option 03: Z Fold Paper Takeup Add \$100.00
- Option 08: 50 Hz Operation Add \$50.00
- Option 09: 230 Volts, 9900-2029 Transformer installed in cabinet Add \$100.00

350 SERIES MEDICAL PREAMPLIFIERS:

- 350-1000B DC Preamplifier \$325.00
- 350-1100CM Carrier Preamplifier with harmonic filter kit installed for use with 267 or 268 Transducers... 425.00
- 350-1300C DC Coupling Preamplifier 250.00
- 350-1500A Low Level Preamplifier 525.00
- 350-2B DC Plug-in with Zero Suppression 190.00
- 350-3A EEG/ECG Plug-in 225.00
- 350-4A DC Strain Gage Plug-in 130.00
- 350-8 Waters Oximeter Plug-in 175.00
- 350-9A Waters Earpiece/Cuvette Plug-in 200.00
- HP Model 6203B Power Supply for use with 350-9A... 169.00
- 350-11A Oxygen Cell Plug-in 140.00
- 350-12 Galvanic Skin Resistance Plug-in 205.00
- 350-15 Thermal Dilution Plug-in 265.00
- 14012A Thermistor Probe (125 cm long) with 10 ft. interconnecting cable and calibration charts — for use with 350-15 190.00
- 350-2700C High Gain Preamplifier 375.00
- 350-3200C8 ECG Accessory Kit, including patient cable, straps, electrodes and Redux 39.00
- 350-2700C8 EEG Accessory Kit, including needle electrodes, disk electrodes, Redux and 25 ft. cable 24.00
- 350-3000C Medical Carrier Preamplifier 325.00
- 350-3200A ECG Preamplifier 325.00
- 350-3200C8 ECG Accessory Kit, including 5 wire patient cable, straps, electrodes and Redux 39.00
- 461-190 Y Cable for taking two separate leads at once with two 350-3200's, using one 350-3200C8 Accessory Kit 33.00
- 350-3400A Cardio-Tach Preamplifier 550.00
- 760-20 Monitor Meter 114.00
- 760-20-120 0-100 beats/min Heart Rate Scale 6.50
- 760-20-121 0-200 beats/min Heart Rate Scale 6.50
- 760-20-122 0-400 beats/min Heart Rate Scale 6.50
- 760-20-140 Blank Scale 3.50
- 651-263P1 4 1/2 foot (1370 mm) cable for connecting 350-3400A to 760-20 Monitor Meter 5.75
- 651-263P2 12 foot (3660 mm) cable for connecting 350-3400A to 760-20 Monitor Meter 6.75
- 651-263P3 20 foot (6100 mm) cable for connecting 350-3400A to 760-20 Monitor Meter 7.75
- 350-3400C9 Cardio-Tach ECG Accessories Kit 23.00
- 350-3600A pH Preamplifier, less electrodes 650.00
- Part No. 461-212 Adapter for pO₂ electrode 222.50
- Part No. 461-215 Switch Box for pH, pCO₂, and pO₂ 382.50
- 350-3700A Integrating Preamplifier 450.00
- 350-5000B Respiratory Preamplifier 550.00
- 267B Pressure Transducer 250.00
- 268B Pressure Transducer 250.00
- 270 Bi-Directional Differential Gas Pressure Transducer 295.00

MANUFACTURING DIVISION:

HP Sanborn Division
175 Wyman Street
Waltham, Massachusetts 02154

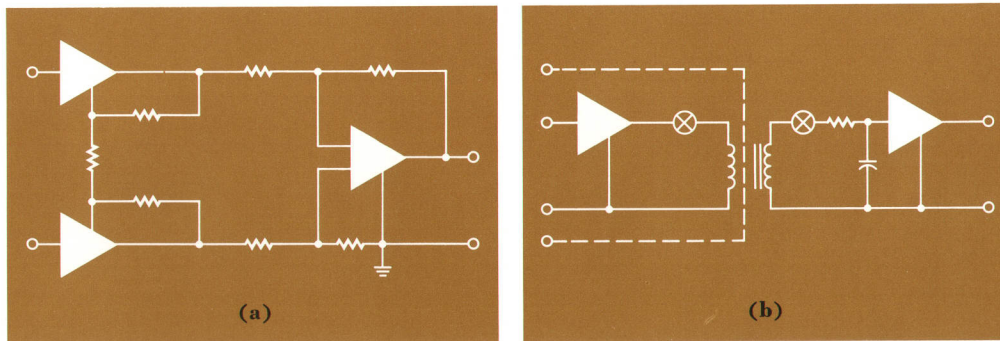

Fig. 1. Two common configurations of data amplifiers are the direct-coupled differential (a) and the carrier-coupled design (b).

Advantages of Direct-Coupled Differential Data Amplifiers

By Morton H. Levin

THE EVOLUTION OF DATA AMPLIFIERS has been dominated by the struggle to find better ways of achieving common mode rejection. Two general approaches have become widely used: direct-coupled 'differential' designs, and carrier-coupled configurations. The differential designs, Fig. 1(a) raise the common-mode input impedance to a very high value by means of feedback. This type of amplifier may be completely direct-coupled, using various isothermal techniques to achieve low offset errors, or it may be chopper-stabilized.

The carrier-coupled designs, Fig. 1(b), modulate the signal at a high frequency, passing this ac signal through a shielded transformer, then demodulating and filtering out the carrier. Using the carrier-coupled system in contrast with the direct-coupled approach, yields ability to reject much larger common mode voltages (up to 1 kV) and achieves slightly higher CMR, but at the expense of increased complexity, decreased linearity and accuracy (since the modulator-demodulator link must operate without overall feedback), and limited bandwidth and transient response. The maximum signal frequency is limited to about 20% of the modulation frequency.

The advantages of chopper-stabilization versus direct-coupled differential circuitry are reduced time and temperature dependent offsets referred to input, but the disadvantages are deteriorated transient response, increased noise, increased complexity, and the cost of the chopper.

Direct-Coupled Differential Amplifiers

Differential amplifiers using transformers and choppers for isolation can offer higher common-mode voltage tolerance than direct-coupled amplifiers. However, direct-

coupled differential amplifiers have other important advantages.

Without choppers there is no chopper intermodulation. This is a distinct advantage where it is necessary to gather high-accuracy data in the presence of noise; with a chopper, noise components in the range of the chopping frequency produce offsets.

In addition, the absence of chopper stabilizing circuitry generally results in a smoother rolloff of the open loop characteristic of the amplifier. There are no deformations due to the chopper circuitry and settling and overload recovery times are generally faster. Where it becomes necessary to multiplex several input signals into one amplifier, the sampling rates can be higher for a fixed system error. Thus it is possible to use fewer amplifiers and reduce system costs.

Higher Bandwidth. Transformer-isolated amplifiers have been generally limited to about 20 kHz, although some newer units appear to be somewhat higher. DC differential amplifier bandwidths may run as high as 1 MHz. Wide bandwidths are necessary to feed a wideband tape recorder, for instance.

Better Linearity. Total feedback can be employed in a direct-coupled differential amplifier, with the feedback loop surrounding everything. There are *no* active elements not surrounded by the feedback loop. In such cases, the feedback loop is all resistive and does not depend upon diodes or transformers. Resistors are characteristically very precise components, thus the amplifier is likely to be capable of the needed higher precision in high-accuracy data acquisition systems.



(a)

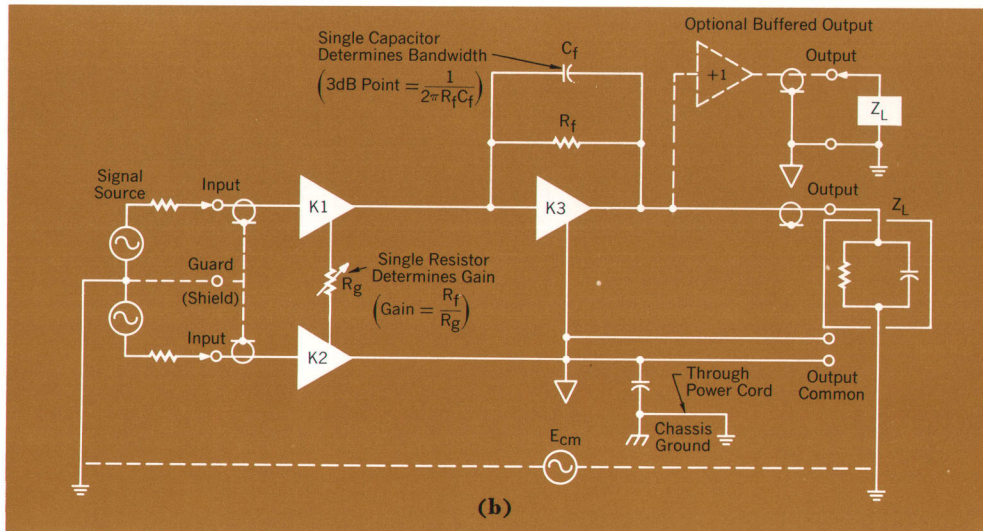

Fig. 2. The new HP Model 2470A Data Amplifier (a) is a differential design consisting of three amplifiers, K1, K2 and K3 (b). Amplifiers K1 and K2 are identical. Power supplies for the three amplifiers are completely isolated from each other to preserve the common mode rejection offered by the design.

Fewer Components. Generally, the direct-coupled amplifiers require fewer components resulting in a more compact amplifier of potentially higher reliability. Less cabinet space is needed in large scale data acquisition systems, and it is more easily possible to achieve longer mean time between failures.

Two New Data Amplifiers. Two direct-coupled, differential data amplifiers have been designed to amplify low-level ac or dc signals encountered in such areas of testing

as pressures, temperature, stress analysis, vibration and flow sensing.

Both amplifiers, the HP Model 2470A, Fig. 2, and the HP Model 8875A, Fig. 3, will supply ± 10 volts at 100 milliamperes into a resistive or reactive load. They may be used to drive analog-to-digital converters, digital voltmeters, galvanometers, oscillographs, and X-Y plotters. In addition, they have the capability of making differential measurements, isolating the source ground from the output ground, impedance conversion, and they apply



(a)

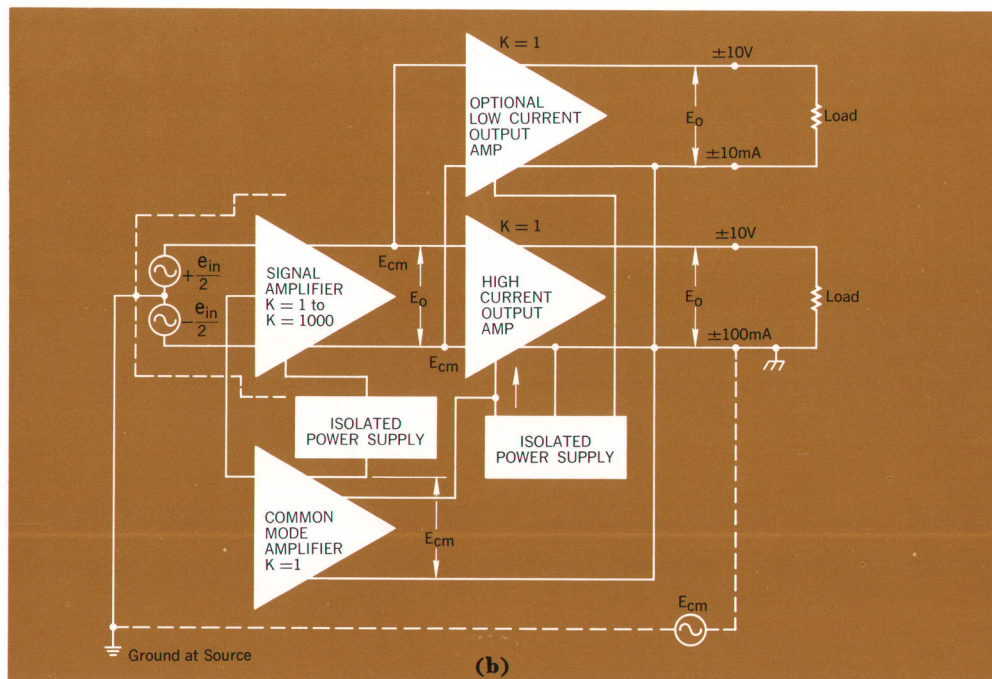

Fig. 3. The HP Model 8875A Data Amplifier (a) uses a common mode amplifier (b) to provide good common mode rejection without the use of a specially shielded power transformer.

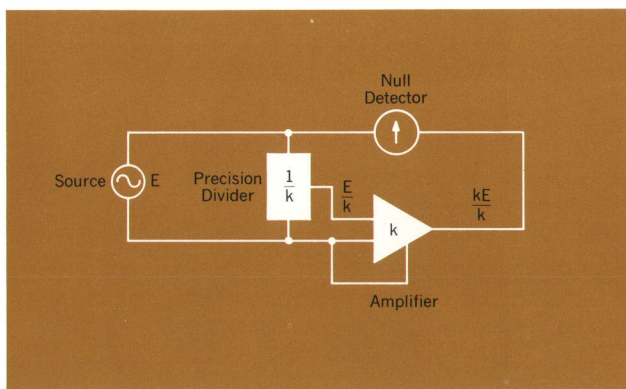

Fig. 4. Use of the bridge method of checking gain linearity of an amplifier with gain K is relatively inexpensive and rapid. Precision depends mainly upon the accuracy of the voltage divider and the sensitivity of the null detector.

well where good rejection of common mode noise is needed. Characteristics of the amplifiers are detailed in the specifications that accompany this article.

Test Precautions

In selecting a data amplifier, the appropriate primary considerations are: (1) zero offsets versus time and temperatures, (2) common mode rejection and maximum common-mode tolerance, (3) gain accuracy, linearity and stability, (4) bandwidth, slewing and transient response, and (5) environmental conditions and reliability. In verifying these specs, certain precautions must be taken or the test results may be misleading.

Common Mode Rejection Ratio. It is not sufficient to merely short the input leads, connect to a source of common-mode voltage and measure amplifier performance, since in nearly all practical situations, the input is unbalanced. To simulate performance under the worst likely conditions, a resistor is placed first in one lead for a test, then the test repeated with the resistor in the other lead. The source resistor must be shielded along with the input leads, or leakage capacity from the resistor to ground will introduce errors in excess of specs.

Offset and Noise. The source resistor and input leads should be shielded and the input leads should also be twisted. This will minimize the amount of 60 Hz noise picked up by the test circuit.

Linearity and Gain Accuracy. These parameters may be checked with a highly accurate standard at the source

and a highly accurate voltmeter at the output. A much less expensive method, the bridge method, Fig. 4, is also much more rapid. Only the precision of the input voltage divider is important as well as the sensitivity of the null detector.

Low frequency noise and zero drift can easily give apparent out-of-spec indications. Measurements made at high gain could be affected by drift and noise. For example, both amplifiers have a full-scale output of 10 volts. At a gain of 1000, full scale input is 10 millivolts and linearity measurements made against a spec of 0.01% require the allowable error be within ± 1 microvolt. In this test, great care must be taken since a noise spike greater than 1 microvolt could make the amplifier look nonlinear.

Overload Recovery and Settling Time. The system used to measure this factor must be checked to insure that it is appreciably faster than the amplifier. Some oscilloscopes have a relatively long recovery time from saturation.

DC Input Impedance. Input impedance is defined as the ratio of the change in input voltage to the resulting change in input current. Transistor circuits always have a small but finite input current flowing. The measuring technique must take this into account or errors will result.

Slewing. The slewing test determines how fast the amplifier will respond to a rapidly changing input. A pure sine wave (symmetrical around zero) is fed in and the dc output measured. If the amplifier characteristics are ideal, there will be no dc output at any frequency. In this test, the ac source must not generate error producing dc. Transformer coupling between the source and amplifier will satisfy the requirement. ■

Regarding 'Precision Thin-Film Coaxial Attenuators'

In the equations on page 13 of the June 1967 issue, the term a is the width of the center conductor and the term D is the distance between the inner edges of the outer conductors. These definitions were inadvertently omitted from the text of the article 'Precision Thin-Film Coaxial Attenuators.'

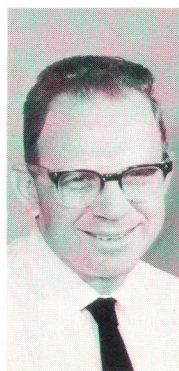

Morton H. Levin

Mort Levin is a graduate of Massachusetts Institute of Technology with the degree of Bachelor of Science in Electrical Engineering. After graduation in 1948, he worked for the National Advisory Committee for Aeronautics at Langley Field, Virginia on instrumentation research.

Mort joined the Hewlett-Packard Sanborn Division in 1953. He has designed several chopper-stabilized amplifiers for Sanborn recording systems and has designed data amplifiers including the HP Model 8875A. He is presently section leader for the Biopotential and Monitoring Section.

Mort is a Senior Member of IEEE.

SPECIFICATIONS

HP Model 8875A Differential Amplifier

BANDWIDTH: DC to 75 kHz within 3 dB. Can be changed by addition of a capacitor; 3 dB points down to 2 Hz can be obtained.

GAIN: Range is from 1 to 1000 in seven fixed steps of 1, 3, 10, 30, 100, 300, and 1000, plus an OFF position.

GAIN ACCURACY: $\pm 0.1\%$.

GAIN STABILITY: $\pm 0.01\%$ at constant ambient temperature for 30 days, $\pm 0.005\%/^{\circ}\text{C}$ (for fixed gain steps only).

GAIN ADJUSTMENT: Gain control covers a $\pm 3\%$ range with sufficient resolution for setting any one gain to $\pm 0.01\%$. A vernier control can be switched in for setting the gain to any desired value between the standard fixed steps. Stability of this control is approximately 2% over a 0–55°C temperature range. This control increases the gain. When it is in its extreme position (gain change at maximum) the bandwidth drops to 30 kHz (3 dB point).

INPUT CIRCUIT: Balanced differential; may be used single-ended. Will accept floating signal sources without requirement for return path to ground.

DIFFERENTIAL INPUT IMPEDANCE: 20 megohms in parallel with less than 0.001 μf .

COMMON MODE REJECTION: At least 120 dB from dc to 60 Hz for up to 500 ohms source impedance in either side of input circuit at gain of 1000; 66 dB min. at gain of 1.

GUARDED COMMON MODE INPUT IMPEDANCE: 2000 megohms in parallel with less than 2 picofarads.

COMMON MODE TOLERANCE: ± 20 volts.

INPUT OVERLOAD TOLERANCE: ± 30 volts differential; ± 70 volts common mode will not damage the amplifier.

DRIFT:

VOLTAGE DRIFT: $\pm 3 \mu\text{V}$ referred to input, $\pm 0.2 \text{ mV}$ referred to output at constant ambient temperature for 30 days; $\pm 1 \mu\text{V}/^{\circ}\text{C}$ referred to input, $\pm 0.2 \text{ mV}/^{\circ}\text{C}$ referred to output.

CURRENT FEED TO SOURCE: 10^{-9} amp max. at constant ambient temperature, $\pm 10^{-9}$ amp/ $^{\circ}\text{C}$.

DRIFT AS A FUNCTION OF SOURCE IMPEDANCE: For unbalanced sources, equivalent input voltage drift is the sum of the voltage drift plus current feed to source times source impedance. For balanced sources, equivalent input voltage drift is approximately $\frac{1}{2}$ the value for unbalanced sources.

OPERATING TEMPERATURE RANGE: 0–55°C. Warmup time for specifications to apply is one hour.

NOISE: Measured with respect to input with 1 K signal source impedance at gain of 1000. Noise measurements with respect to input are:

BANDWIDTH	10 K source — noise approximately double
dc — 10 Hz	1 microvolt p-p
dc — 100 Hz	3 microvolts p-p
dc — 1 kHz	6 microvolts p-p
dc — 10 kHz	3 microvolts rms
dc — 50 kHz	4 microvolts rms
dc — 250 kHz	5 microvolts rms

10 K source — noise increases by approximately 5X.

OUTPUT CIRCUIT: ± 10 volts across 100 ohms, (100 mA) and 0.2 ohms max. output impedance at dc. Short circuit proof. Current limited to approximately 150 mA. Will not oscillate with any value of capacitance load. Magnitude of capacitance load is governed only by output capability of amplifier.

NON-LINEARITY: Less than 0.01% of full scale value, 10 volts.

SETTLING TIME: 100 μs to 99.9% of final value for a step input.

OVERLOAD RECOVERY TIME: Recovers to within 10 μV referred to input plus 10 mV referred to output in 10 ms for a differential overload signal of ± 10 volts at gains of 300 to 1000, and 1 ms at gains of 1 to 100. For a 10 times full scale overload of any duration: 2 ms for gains of 300 to 1000 and 100 μs for gains of 1–100.

SLEWING:

OUTPUT CIRCUIT: With resistive load of 100 ohms or greater 10^6 V/s for 10 mV shift in dc output.

INPUT CIRCUIT: Gain of 1, $2.5 \times 10^6 \text{ V/s}$ for 10 mV shift in dc output; gain of 3, $0.83 \times 10^6 \text{ V/s}$ for 10 mV shift in dc output. For gains greater than 3, output circuit determines slewing rates.

POWER: 115/230 volts $\pm 10\%$, 50–400 Hz, 6 watts.

DIMENSIONS: 4 $\frac{3}{4}$ " high x 1 $\frac{1}{2}$ " wide x 15" deep (121 x 40 x 381 mm).

PRICE: Model 8875A, \$495.00.

MANUFACTURING DIVISION: SANBORN DIVISION
175 Wyman Street
Waltham, Massachusetts 02154

HP Model 2470A Data Amplifier

DC GAIN:

STANDARD: 5 fixed steps of X10, X30, X100, X300, X1000, selected at front panel. A X0 position shorts the output.

OPTION M1: 4 fixed steps of X1, X10, X100, X1000, selected at front panel. A X0 position shorts the output.

SPECIAL: On special order, any fixed steps between X1 and X1000 can be provided, with a maximum of 6 positions.

VERNIER (Option M3): 10-turn potentiometer (front panel) extends gain up to X3.5, for any gain setting.

DC GAIN ACCURACY:

CALIBRATED GAIN: 0.01% (resolution of gain trim adjustment). (Factory calibrates gain of 10.)

OTHER GAINS: 0.03%, consisting of 0.02% gain-to-gain accuracy and 0.01% gain trim resolution.

VERNIER (Option M3):

Dial Accuracy: $\pm 3\%$.
Resolution: $\pm 0.05\%$.
Resettability: $\pm 0.08\%$.

GAIN STABILITY:

DC: $\pm 0.005\%$ per month.
AC: $\pm 0.1\%$ per month, for dc to 2 kHz.
TEMP. COEFF.: $\pm 0.001\%$ per $^{\circ}\text{C}$.

LINEARITY:

DC: $\pm 0.002\%$ of full scale, referred to straight line through zero and full scale output. Applies for all gain settings and inputs of both polarities.

AC: $\pm 0.01\%$ of full scale referred to straight line through zero and full scale output. Applies for all gain settings and inputs to 2 kHz.

ZERO DRIFT (OFFSET): Figures below apply to any gain setting; there is no need to adjust zero on changing gain setting.

PER DAY: $\pm 5 \mu\text{V rti}$ $\pm 50 \mu\text{V rto}$
PER MONTH: $\pm 25 \mu\text{V rti}$ $\pm 250 \mu\text{V rto}$
TEMP. COEFF.: $\pm 1 \mu\text{V}$ $\pm 0.5 \text{ namp rti}$ $\pm 10 \mu\text{V rto}$ per $^{\circ}\text{C}$.

MAXIMUM INPUT SIGNAL: $\pm 11 \text{ V}$, differential plus common mode. Combined input up to $\pm 20 \text{ V}$ will not damage instrument.

DIFFERENTIAL INPUT IMPEDANCE: 1000M shunted by 0.001 μf .

COMMON MODE REJECTION: 120 dB at 60 Hz, for gain settings of X30 and higher. (60 Hz CMR decreases to 110 dB at X10, 90 dB at X1.) CMR at dc is 120 dB for all gain settings.

COMMON MODE RETURN: From input common to output common: 1 megohm, max. (Provided internally when input lead shields are connected to either side of input.)

NOISE:

0 to 10 Hz	1 μV p-p rti and 10 μV p-p rto.
0 to 100 Hz	3 μV p-p rti and 30 μV p-p rto.
0 to 1 kHz	1 μV rms rti and 30 μV rms rto.
0 to 10 kHz	3 μV rms rti and 300 μV rms rto.
0 to 50 kHz	5 μV rms rti and 500 μV rms rto.

OUTPUT: $\pm 10 \text{ V}$ max. 0 to 100 mA. Self-limits at approx. 11.5 V, 300 mA.

OUTPUT IMPEDANCE: 0.1 Ω in series with 10 μh max.

LOAD CAPABILITY: 100 Ω or 0.01 μf for full output. Amplifier remains stable and is undamaged by short circuit or capacitive load up to 0.5 μf lumped capacity.

SLEWING: 10^6 V/s rti , 10^7 V/s rto (inputs of both polarities) with dc offset caused by slew limiting less than 0.1% of peak ac, provided full scale input is not exceeded.

This assures full scale output over the entire bandpass, except with 2470A-M1 at gain of 1, which slew limits above 16 kHz.

BANDWIDTH: (For any gain step.)*

0 to 50 kHz	$\pm 3 \text{ dB}$
0 to 15 kHz	$\pm 1 \text{ dB}$
0 to 5 kHz	$\pm 1\%$
0 to 1.5 kHz	$\pm 0.1\%$
0 to 500 Hz	$\pm 0.01\%$

(*With optional vernier, 3 dB bandwidth is 20 kHz at X3.5 gain setting.)

NOTE: Other fixed 3 dB bandwidths between 10 Hz and 50 kHz available on special order.

SETTLING TIME: 100 μs to within 0.01% of final value.

OVERLOAD RECOVERY: Settling time plus 100 μs for signal of 10 times full scale, but less than 10 V. Less than 5 ms for signal plus common mode up to 20 V.

DUAL OUTPUT: Second, buffered output, with same level and phase as standard output, available as Option M5.

DC GAIN: X1 (referred to main output).

DC GAIN ACCURACY: $\pm 0.01\%$.

DC GAIN STABILITY: $\pm 0.02\%$ per month. (Temp. coeff. $\pm 0.005\%$ per $^{\circ}\text{C}$.)

DC LINEARITY: $\pm 0.02\%$ of full scale.

ZERO DRIFT: $\pm 0.005\%$ of full scale rto per day. (Temp. coeff. $\pm 0.001\%$ of full scale per $^{\circ}\text{C}$.)

OUTPUT: $\pm 10 \text{ V}$ max. 0 to 10 mA. Self-limits at approx. 11.5 V, 35 mA.

OUTPUT IMPEDANCE: 0.5 Ω in series with 10 μh max.

LOAD CAPABILITY: 1 K or 0.001 μf for full output. Amplifier remains stable and is undamaged by short circuit or any capacitive load, and main output is affected less than $\pm 0.005\%$.

SLEWING: Full output available at specified 3 dB bandwidth ($3 \times 10^6 \text{ V/s}$ max. at 50 kHz).

BANDWIDTH: Any fixed 3 dB bandwidth between 100 Hz and 50 kHz, specified by customer. Must be less than or equal to 3 dB bandwidth of main output. 12 dB/octave slope.

SETTLING TIME: Determined by bandwidth specified.

OVERLOAD RECOVERY: Cannot be overloaded by main output. Recovers from a short on its output in 2X settling time.

ENVIRONMENTAL CONDITIONS:

OPERATING: Ambient temperatures from 0 to 55°C. Relative humidity up to 95% at 40°C. When used individually, instruments are self-cooled by convection. Accessory Combining Case includes fan for additional cooling.

STORAGE: -40 to $+75^{\circ}\text{C}$.

RELIABILITY: Predicted mean time between failures (with 90% confidence) is 20,000 hours — when operated at 25°C ambient.

POWER REQUIRED: 115/230 V $\pm 10\%$, 50 to 400 Hz, 8 W with no load, 10 W at full load. Fuse, 115/230 V and on/off switches on rear panel. Fan in combining case operates from 50 to 60 Hz only.

PRICE: Model 2470A, \$585.00.

MANUFACTURING DIVISION: DYMEC DIVISION
395 Page Mill Road
Palo Alto, California 94306

Errors in Data Amplifier Systems

Possible error sources in a data amplifier system and how they affect the choice of an amplifier.

By Richard Y. Moss II

DATA AMPLIFIER SYSTEMS acquire information representing physical phenomena such as temperature, pressure, displacement, velocity and acceleration. The system translates this information into an electrical signal by means of a transducer, performs a conditioning operation upon the electrical signal such as amplification, bandwidth modification, or other changes necessary to make the information more useable. The information of interest is displayed or recorded on output devices of various types.

Errors may be introduced into the data by the amplifier itself or by other parts of the system. Before discussing errors, an overall look at a data amplifier system is helpful. A system typically is three major blocks: (1) Signal source, (2) Data amplifier and (3) Output device.

Signal Sources. Most transducers are passive elements whose resistance, capacitance, or inductance varies in proportion to some environmental stimulus. Such transducers are electrically excited by an appropriate power source to yield a signal. There are several exceptions to this generalization, however, so it is worthwhile to examine some of the more popular transducer types according to their primary electrical characteristics:

(1) Voltage sources: thermocouples, and signal sources such as batteries, and electronic circuits are examples, Fig. 1(a). Typical potentials are from microvolts to volts, at impedance levels from ohms to thousands of ohms.

(2) Current sources: photomultiplier tubes, and PIN photodiodes are very nearly ideal current generators with outputs in the microampere region. Piezoelectric crystals are ac charge-generating devices and may also be considered in this class represented in Figs. 1(b), (c) and (d).

(3) Resistance devices: strain gages and strain gage bridges, resistance thermometers (both metal and semiconductor), and potentiometers are among the more popular members of this extensive class of devices, Figs. 1(e) and (f). The signals produced are similar to those in the voltage source class, except that the bridge-connected devices have no output terminal in common with their source of excitation voltage, and hence are sources of common-mode voltage as well as signal voltage.

(4) Inductance devices: variable inductors, and variable ratio transformers are included in this class, Figs. 1(g) (h). These transducers must be excited by ac to produce constant level signals, but produce transient signals with a dc pulse.

(5) Capacitance devices: semiconductor voltage-variable and mechanically-variable capacitors operate in a manner analogous to the inductance devices, and are represented by Fig. 1(i). The capacitance transducer for displacement measurement is an example.

Conditioning Operations

Among the operations which may be performed by a data amplifier are impedance changing and voltage gain. Certain sources, such as a standard cell, should not be loaded, and a high amplifier input impedance is desirable to avoid drawing current from the cell. The amplifier output usually represents a source impedance of less than an ohm to its load.

In some cases, such as a resistance strain gage, the source impedance may be varying. Here the amplifier as a buffer, provides a constant impedance to its load.

Bandwidth shaping nearly always takes the form of a low pass filter in data amplifiers, usually with a steep slope in the cutoff region, and usually with variable upper cutoff frequency, although occasionally ac-coupled amplifiers with variable lower cutoff frequency are required. A common need for filtering arises because the input signal contains noise components, perhaps as a result of sampling, which can be separated from the information components. The price paid in this case for low pass filtering is loss of high frequency information, which may be needed in dealing with transients.

Ground potential translation includes two phenomena: common mode rejection (CMR), wherein it is desired to amplify a small difference between two large signals; and control of circulating currents between signal source ground and output load ground, whether caused by actual ground potential difference in the environment or by injected ground currents from the instrumentation. Ground current control is often the most important func-

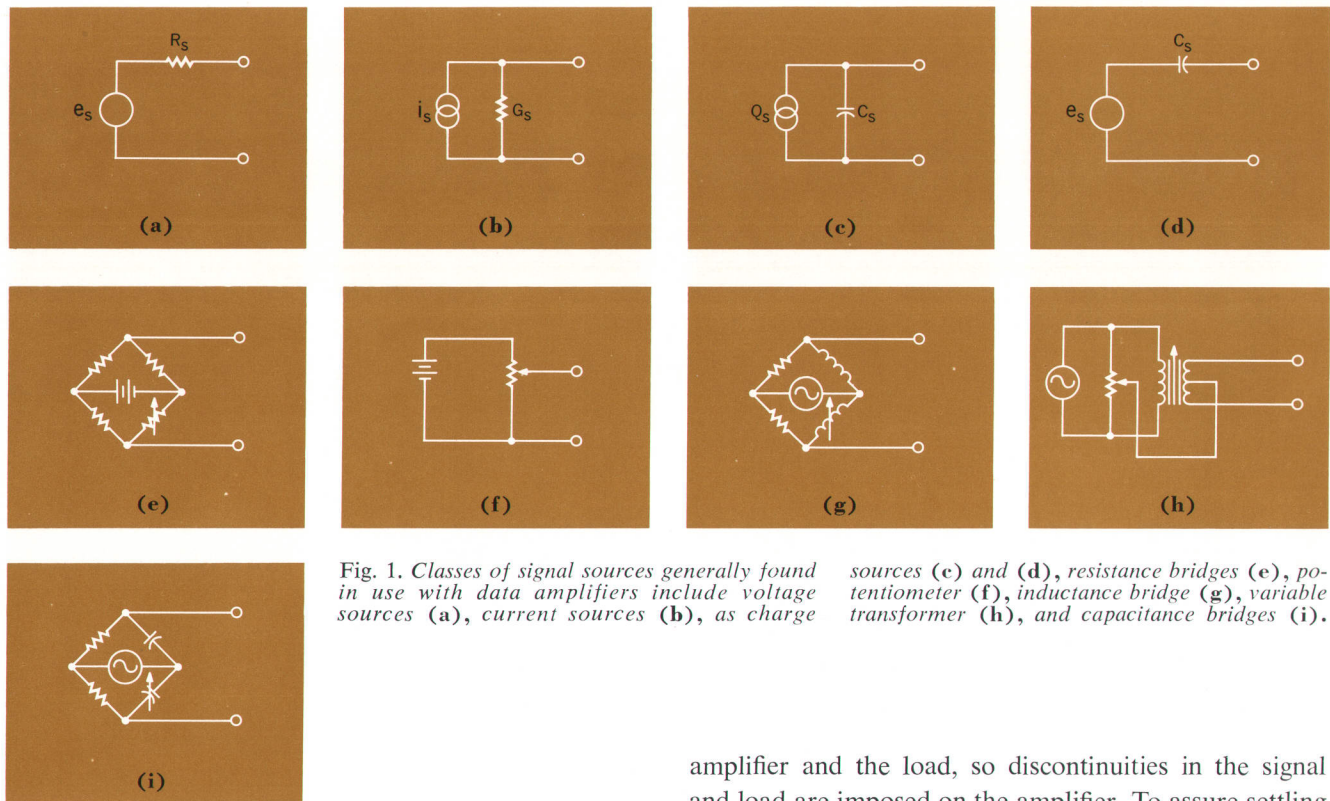

Fig. 1. Classes of signal sources generally found in use with data amplifiers include voltage sources (a), current sources (b), as charge sources (c) and (d), resistance bridges (e), potentiometer (f), inductance bridge (g), variable transformer (h), and capacitance bridges (i).

tion performed by a data amplifier, because ground potential differences between signal source and amplifier are often larger than the desired signal.

Output Devices

The output of the data amplifier may be monitored by a visual display instrument such as a meter or oscilloscope, in which case the use of the amplifier is similar to that of a laboratory measuring instrument, i.e. is as an instrument whose readings are observed in real time rather than being recorded. Often the load is a galvanometer, stripchart recorder, X-Y plotter, or FM tape recorder, so that the output signal may be recorded for future reference.

The amplifier output signal may be converted to a digital code by an analog-to-digital converter or digital voltmeter, and the subsequent coded signal stored by any of a variety of devices including magnetic tape, punched tape, punched cards, or computer memory device. Such digital systems are capable of storing vast quantities of data with high resolution, and consequently make more severe demands upon amplifier noise, accuracy, linearity, and reliability characteristics.

Often there will be feedback from the computing element to a production process which is being monitored by the signal source transducers. Also, it is common for signal scanning devices to be interposed between the signal source and the amplifier, as well as between the

amplifier and the load, so discontinuities in the signal and load are imposed on the amplifier. To assure settling to the required accuracy and to be sure that unanticipated overloads will not cause errors in a subsequent signal, transient response must be properly specified.

Types of Errors

To specify a data amplifier for a system, the possible sources of error must first be examined and understood. Sources of error contributed by the amplifier are listed in the specifications of the instrument. In a direct-coupled low frequency system, the dc errors will usually dominate. In a wideband system, there are analogous ac considerations which contribute additional errors. There are also system errors which arise because input signal amplitudes are not completely predictable or because of the increased number of components due to the size of the system increases likelihood of failures.

DC Error Sources. In the case of a low frequency system, such as the typical analog recording system or an amplifier-per-channel digital system, the dominant error sources are of two types: offset errors, and slope errors. To accurately specify offset (or zero offset, as it is more commonly called), one must distinguish the portion of the offset which is gain-dependent, and hence must be quoted 'referred-to-input' (RTI), from the constant portion, which is not gain-dependent, and hence is quoted 'referred-to-output' (RTO), Fig. 2(a). The RTI offset further subdivides into a source resistance dependent term and a constant term, so that it is necessary to quote

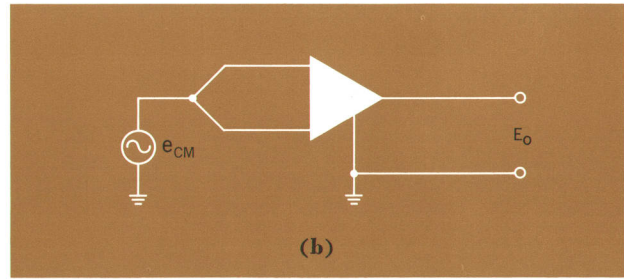
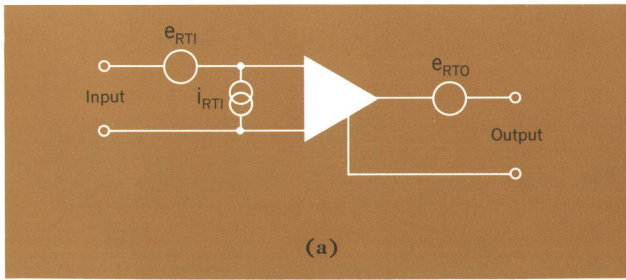

Fig. 2. Offset voltage and offset current (a), both referred-to-input because they are gain-dependent, and the voltage referred-to-output which is not gain-dependent, are the major parameters in determining total offset. Insufficient common-mode-rejection is another source of offset error (b). The common mode signal at the output is equal to $e_{CM} \left(\frac{\text{Gain}}{\text{CMR}} \right)$.

both offset voltage RTI and offset current RTI, as well as offset voltage RTO. These three specifications completely determine the amplifier offset error for a given gain setting and source resistance. All three parameters must be known as functions of time and temperature to predict the possible error in the system environment.

Another source of offset error is insufficient common mode rejection (CMR). When the amplifier input terminals are both at the same potential but not at amplifier ground, Fig. 2(b), some fraction of this common mode voltage may be amplified and appear at the output terminals of the amplifier, indistinguishable now from the expected output signal. The ratio of the common mode voltage to the equivalent differential signal which would have produced the same output is called the common mode rejection (CMR). Another way of stating this is that CMR is the ratio of differential gain to common mode gain. To preserve system accuracy, the CMR should remain high at all gain settings, and with worst-case source impedance unbalance conditions.

Errors in the slope of the input-output curve of the amplifier may be due to gain inaccuracy, loading, or

linearity problems. The accuracy of the gain is determined by the precision of the attenuator or feedback resistors, and errors caused by finite gain inside the loop. The resulting errors are expressed as a function of the signal amplitude, time and temperature. Insufficient feedback can also contribute to linearity errors; that is, the departure of the input-output curve from a straight line. The only useful specification is 'terminal' linearity, where the straight line is drawn exactly through zero and full scale, Fig. 3(a). A 'best straight line,' Fig. 3(b), approach makes normal zero and full scale calibration procedures meaningless since the 'best' line usually does not run through the full-scale point, but runs instead through other points on the input-output curve whose location is chosen to produce the smallest numbers for the specification. However, they are unrelated to conditions of real use.

Loading errors, resulting from the loading of the signal source by the amplifier input circuits, or reduction of the amplifier output signal by load circuits, may be considered as gain slope errors, since the effect is the same. Certain types of reactive loads or sources, however, may

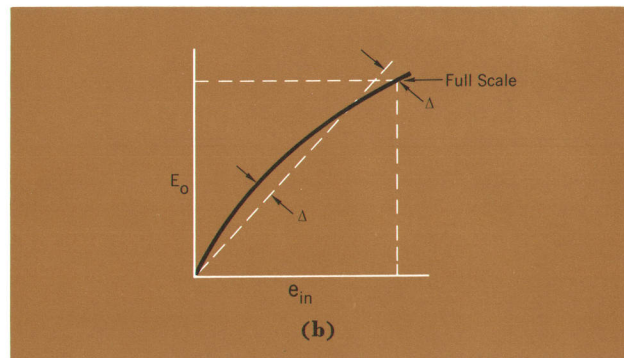
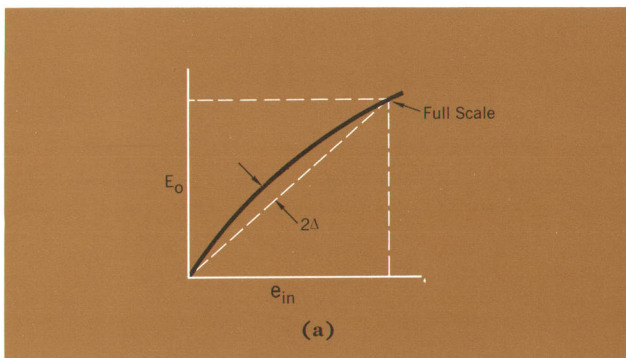

Fig. 3. Comparing the 'terminal linearity' method of specifying gain accuracy (a) with the 'best straight line' method (b) shows that while the 'best straight line' method results in better numbers on specifications, the 'terminal linearity' method results in a more accurate statement of real usefulness.

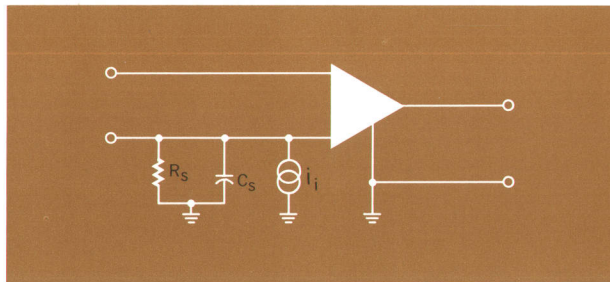

Fig. 4. Sources of additional offset error are due to injected current, i_i , source resistance and capacitance.

result in nonlinearity, slew limiting,* or even oscillation, and must be avoided. For example, a pure sine wave which has been distorted by slew limiting will acquire a dc component, as well as harmonics, and hence can cause low-frequency error.

AC Error Sources. In the case of a wideband system, such as a high speed digital system, there are error sources in addition to those in the lower frequency case. Additional 'offset' errors are due to noise, Fig. 4, which should be specified as a voltage and current RTI and a voltage RTO, but are also a function of the bandwidth. Excess noise in the low frequency region, due primarily to the characteristic semiconductor noise that is inverse to frequency, distorts the otherwise uniform spectrum of the predominantly thermal noise. AC common mode signals produce an output signal in the same manner as the dc common mode case, except that stray capacitances are usually causative elements rather than stray resistances. Another mechanism, which may cause noise in electronic instrumentation not properly shielded or grounded, is 'injected' current such as ac power line leakage into circuits with floating power supplies. This results in a common mode current circulating in a manner analogous to a system with poor CMR.

The similarity to the dc case carries over into the area of slope errors: AC gain errors are generally specified under the heading of 'frequency response'; loading errors

* The term 'slew limiting' deserves some explanation: the slew limit of an amplifier is the maximum rate of change of signal $(dv/dt)_{max}$ which the amplifier can follow linearly. Slew limiting occurs when the current required to produce a voltage across a capacitor ($i = C \frac{dv}{dt}$) exceeds the maximum current available at that stage within the amplifier circuitry. It is also possible for the current requirements of the load, especially when it is capacitive, to impose a slew limit upon the system which is less than the amplifier no-load slew limit. For example: A 20-volt peak-to-peak sine wave at 50 kHz requires 3×10^6 volts/s slewing capability to reproduce it, and a 0.03 μ fd load capacitor would require 100 mA peak output current to develop this signal. For a sine wave

$$\left(\frac{dv}{dt}\right)_{max} = E_{pk}\omega = 2\sqrt{2}\pi e_{rms} f,$$

where E_{pk} = peak voltage, e_{rms} = rms voltage of the sine wave, and f = frequency.

must consider impedance rather than just resistance, and linearity errors result in the generation of distortion components such as harmonics, intermodulation, and even dc offsets.

System Error Sources. Two additional types of errors should be considered when specifying an amplifier for systems use. The first is transient response, not only to signals with short rise times, but also in the case where the input connection is switched, as with a scanner, or where the amplifier has been overloaded in some way. Rapid recovery in all these cases is necessary to prevent blocking the proper operation of the system long after the input signal has returned to proper limits, and to prevent damage to the amplifier.

The second consideration is reliability, a factor which becomes especially significant where several hundred signals are to be amplified in a test which is costly or even impossible to repeat. Unfortunately, specifying reliability in impressive statistical terms is not valid unless the goal was designed into the entire system. Inspecting does not guarantee reliability, but rather attempts to discover information which will indicate whether the goal was achieved. A valid specification must include three elements: a measure of the predicted reliability (such as mean time between failures), the environmental conditions under which this prediction was assumed (such as temperature, humidity, vibration, etc.), and a measure of the confidence of the prediction (which indicates the extent of sample testing necessary). ■



Richard Y. Moss II

After receiving his Bachelor of Science in Electrical Engineering from Princeton University in 1958, Dick Moss worked as a development engineer in missile guidance electronics equipment. He received his MS in EE from Stanford University in 1960 and joined the Dymec Division of Hewlett-Packard as a development engineer.

At Dymec, Dick designed the frequency counter and control logic of the HP Model 2401A Integrating Digital Voltmeter. He has been project engineer on the HP Model 2460A Operational Amplifier, and was project manager for the HP Model 2212A Voltage to Frequency Converter. He became project manager on the HP Model 2470A Differential Data Amplifier in 1964.

Dick is responsible for two patent applications relating to differential amplifiers. He is also the author of two articles in major electronics magazines in recent years.